

Driveways and Curb Cuts

Can I cut the curb to widen my driveway?

Maybe. There are regulations regarding making your driveway wider. Cutting the curb requires approval and issuance of a right-of-way permit.

What are the driveway standards?

The maximum width of the driveway is based on how wide your street frontage is:

- Under 50 feet of frontage- 20 feet maximum
- 50-79 feet of frontage- 26 feet
- More than 79 feet- 30 feet

However, driveways between 30 and 50 feet are allowed if at least 40 feet of *total* street frontage (that is not part of the driveway) remains. See the site plan example on the back. This can be one continuous 40-foot section or broken into other smaller sections. Corner lots also need to meet additional setbacks. In no case are you allowed a driveway more than 50 feet wide. Property with over 100 feet of frontage may be allowed an additional driveway,

Can I get a Variance?

Possibly, but usually not. A variance can only be used when there is something limiting on the property, like a stream, or a hill that prevents you from being able to use the site. It's not a tool that lets someone ask for a larger or smaller structure. If you think there is something limiting on your property, see City staff to discuss.

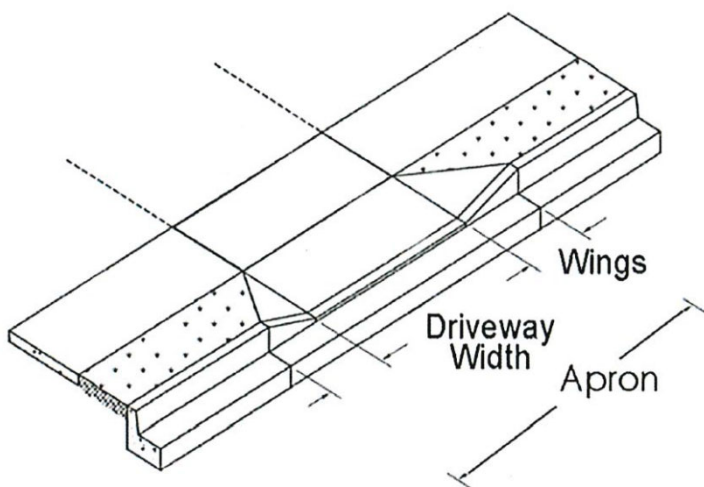

What kind of permit do I need?

You will need to have an approved right-of-way permit before you cut your curb (widen your driveway).

A right-of-way permit can be applied for at Millersburg City Hall. You will need to complete the permit application and include a site plan. The site plan and other requirements are outlined in the Permit Application and can be found on the City website.

How do I cut the curb?

This is important. Back in the old-days concrete contractors would cut the curb vertically. Doing this lets water seep into the ground under the curb. That's no good. Therefore, the City requires a horizontal cut for driveways. Your right-of-way permit will specify these requirements.



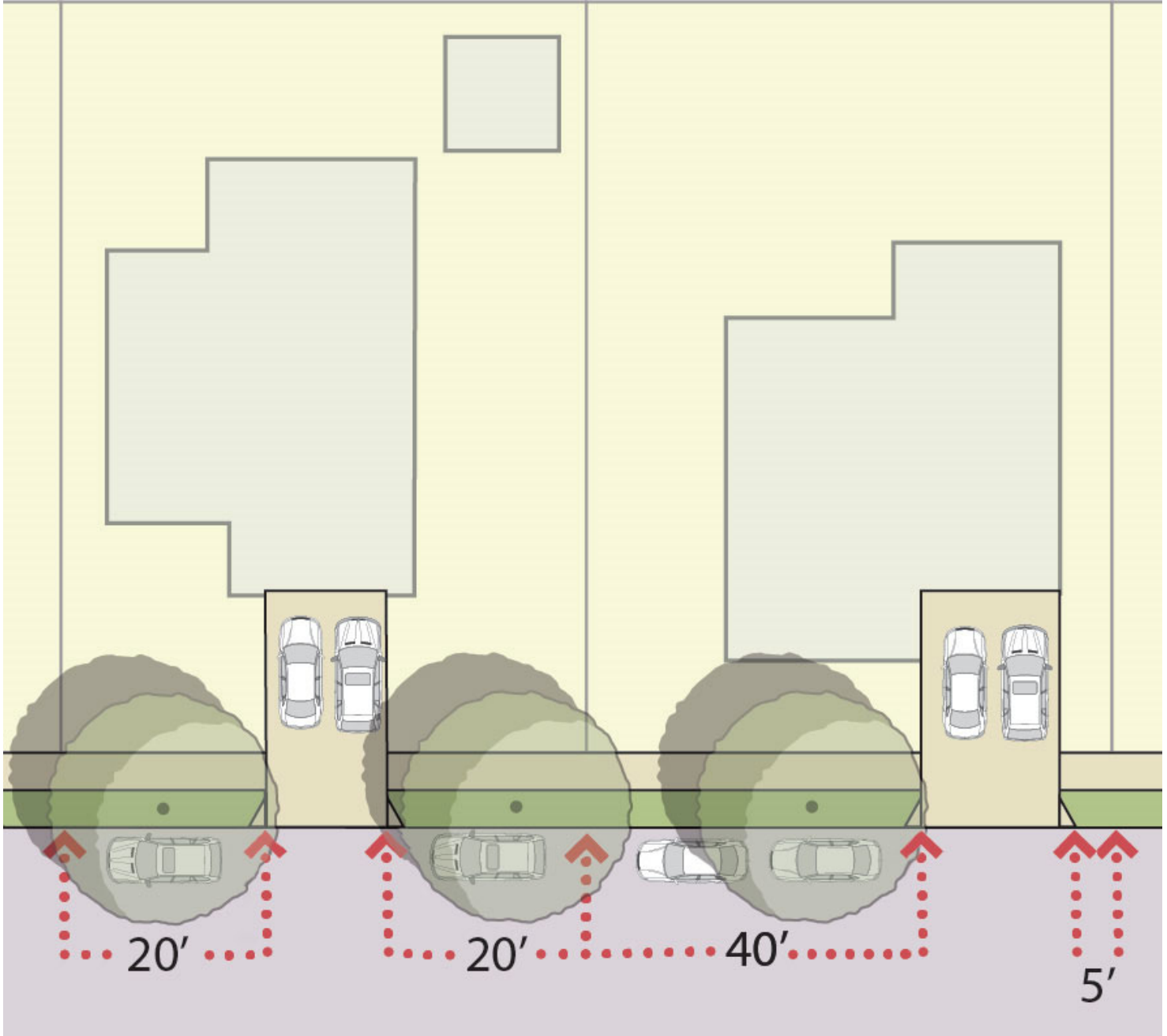

What are the setbacks?

Side	5 feet from the outside edge of the wing to property line
Corner Lot	20 feet from the intersection of the tangent of the property lines
Max Grade	15%

What code sections does this come from?

Chapter 3.02.040, Access Standards, of the Millersburg Development Code regulates driveways.